

121 Battery, Starter, Alternator

121

| | | | |
|--|-------|--|--------|
| GENERAL | 121-1 | Voltage regulator, removing and installing . . . | 121-6 |
| CHARGING SYSTEM | | Alternator brushes, inspecting and replacing . | 121-7 |
| TROUBLESHOOTING | 121-2 | STARTER SERVICE | 121-7 |
| Charging System Quick-Check | 121-2 | Starter Troubleshooting | 121-7 |
| Static current draw, checking | 121-2 | Starter, removing and installing (4-cylinder engine) | 121-8 |
| BATTERY SERVICE | 121-3 | Starter, removing and installing (6-cylinder engine with manual transmission) | 121-8 |
| Battery Testing | 121-3 | Starter, removing and installing (6-cylinder engine with automatic transmission) | 121-9 |
| Hydrometer Testing | 121-3 | Solenoid switch, removing and installing . . . | 121-10 |
| Battery Open-Circuit Voltage Test | 121-4 | | |
| Battery Load Voltage Test | 121-4 | | |
| Battery Charging | 121-4 | | |
| ALTERNATOR SERVICE | 121-4 | | |
| Charging system, checking | 121-4 | | |
| Alternator, removing and installing (4-cylinder engine) | 121-5 | | |
| Alternator, removing and installing (6-cylinder engine) | 121-6 | | |
| | | TABLES | |
| | | a. Battery, Starter and Charging System Troubleshooting | 121-2 |
| | | b. Specific Gravity of Battery Electrolyte at 80°F (27°C) | 121-3 |
| | | c. Open-Circuit Voltage and Battery Charge | 121-4 |
| | | d. Battery Load Test—Minimum Voltage | 121-4 |

GENERAL

The charging system consists of a belt-driven alternator with integral voltage regulator and a battery mounted in the luggage compartment.

Various versions of alternators, voltage regulators, starters, and batteries are used in the E36 cars. It is important to replace components according to the original equipment specification. Check with an authorized BMW dealer for specific application and parts information.

WARNING —

- Wear goggles, rubber gloves, and a rubber apron when working around batteries and battery acid (electrolyte).
- Battery acid contains sulfuric acid and can cause skin irritation and burning. If acid is spilled on your skin or clothing, flush the area at once with large quantities of water. If electrolyte gets into your eyes, flush them with large quantities of clean water for several minutes and call a physician.
- Batteries that are being charged or are fully charged give off explosive hydrogen gas. Keep sparks and open flames away. Do not smoke.

CAUTION —

- Prior to disconnecting the battery, read the battery disconnection cautions given at the front of this manual on page viii.
- Disconnecting the battery cables may erase fault codes stored in control unit memory.
- Always disconnect the negative (–) battery cable first and reconnect it last. Cover the battery post with an insulating material whenever the cable is removed.
- After reconnecting the battery, the power window motors must be reinitialized. See 511 Door Windows.
- Never reverse the battery cables. Even a momentary wrong connection can damage the alternator or other electrical components.
- Battery cables may be the same color. Label cable before removing.

GENERAL

CHARGING SYSTEM TROUBLESHOOTING

Charging system diagnostics requires special test equipment. If the test equipment is not available, charging system fault diagnosis can be performed by an authorized BMW dealer or other qualified repair shop. A general troubleshooting guide is given in **Table a**.

Charging System Quick-Check

As a quick-check, use a digital multimeter to measure voltage across the battery terminals with the key off and then again with the engine running. The battery voltage should be about 12.6 volts with key off and approximately 14.0 volts with the engine running. If the voltage does not increase when the engine is running, there is a fault in the charging system.

NOTE —

The regulated voltage (engine running) should be between 13.5 and 14.5, depending on temperature and operating conditions. If the voltage is higher than 14.8, the voltage regulator is most likely faulty.

Check for clean and tight battery cables. Check the ground cable running from the negative (-) battery terminal to the chassis and the ground cable running from the engine to the chassis. Check the alternator drive belt condition and tension.

Static current draw, checking

If the battery discharges over time, there may be a constant drain or current draw on the battery. A small static drain on the battery is normal, but a large drain will cause the battery to quickly discharge. Make a static current draw test as the first step when experiencing battery discharge.

1. Make sure ignition and all electrical accessories are switched off.
2. Disconnect battery negative (-) cable.

CAUTION —

Prior to disconnecting the battery, read the battery disconnection cautions given at the front of this manual on page vii.

3. Connect a digital ammeter between negative battery post and negative battery cable to measure current. See Fig. 1. Wait at least one minute to get an accurate reading.

A range of about 0 to 100 milliamps is normal, depending on the number of accessories that need constant power. A current of 400 milliamps (0.4 amp) or more may indicate a problem.

Table a. Battery, Starter and Charging System Troubleshooting

| Symptom | Probable Cause | Corrective Action |
|--|---|---|
| 1. Engine cranks slowly or not at all, solenoid clicks when starter is operated. | a. Battery cables loose, dirty or corroded. b. Battery discharged. c. Body ground strap loose, dirty or corroded. d. Poor connection at starter motor terminal 30. e. Starter motor or solenoid faulty. | a. Clean or replace cables. See 020 Maintenance Program . b. Charge battery, test and replace if necessary. c. Inspect ground strap, clean, tighten or replace if necessary. d. Check connections, test for voltage at starter. Test for voltage at neutral safety or clutch interlock switch. e. Test starter. |
| 2. Battery will not stay charged more than a few days. | a. Short circuit draining the battery. b. Short driving trips and high electrical drain on charging system does not allow battery to recharge. c. Drive belt(s) worn or damaged. d. Battery faulty. e. Battery cables loose, dirty or corroded. f. Alternator or voltage regulator faulty. | a. Test for excessive current drain with everything electrical in the vehicle off. b. Evaluate driving style. Where possible, reduce electrical consumption when making short trips. c. Inspect or replace multi-ribbed belt(s). See 020 Maintenance Program . d. Test battery and replace if necessary. e. Clean or replace cables. See 020 Maintenance Program . f. Test alternator and voltage regulator. |
| 3. Battery losing water. | a. Battery overcharging. | a. Test voltage regulator for proper operation. |
| 4. Lights dim, light intensity varies with engine speed. | a. Drive belt(s) worn or damaged. b. Alternator or voltage regulator faulty. c. Body ground straps loose, dirty or corroded. | a. Inspect or replace multi-ribbed belt(s). See 020 Maintenance Program . b. Test alternator and voltage regulator. c. Inspect ground straps, clean, tighten or replace as necessary. |

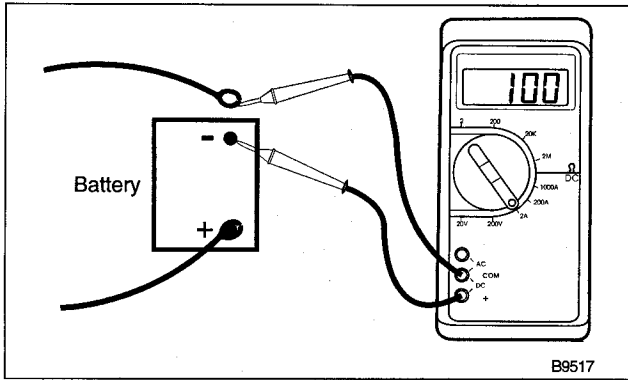

Fig. 1. Electrical system static current draw being measured.

To determine the circuit or component causing the problem, remove one fuse at a time until the current drops to a normal range.

BATTERY SERVICE

The E36 uses a six-cell, 12-volt lead acid battery mounted in the luggage compartment. See Fig. 2.

NOTE —

E36 convertible models require a special battery which is designed for constant vibration. A battery not designed for this will fail much earlier.

Battery capacity is determined by the amount of current needed to start the vehicle, and by the amount of current consumed by the electrical system.

BMW batteries are rated by ampere/hours (Ah) and cold cranking amps (CCA) rating. The Ah rating is determined by the average amount of current the battery can deliver over time without dropping below a specified voltage. The CCA is determined by the battery's ability to deliver starting current at 0° F (-18° C) without dropping below a specified voltage.

Battery Testing

Battery testing determines the state of battery charge. On conventional or low-maintenance batteries the most common method of testing the battery is that of checking the specific gravity of the electrolyte using a hydrometer. Before testing the battery, check that the cables are tight and free of corrosion. See Fig. 2.

Hydrometer Testing

The hydrometer consists of a glass cylinder with a freely moving float inside. When electrolyte is drawn into the cylinder, the level to which the float sinks indicates the specific

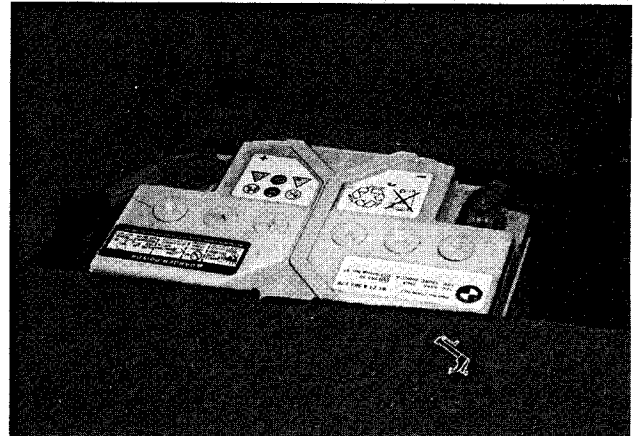

Fig. 2. Battery in right side of luggage compartment.

gravity of the electrolyte. The more dense the concentration of sulfuric acid in the electrolyte, the less the float will sink, resulting in a higher reading and indicating a higher state of charge).

NOTE —

Electrolyte temperature affects hydrometer reading. Check the electrolyte temperature with a thermometer. Add 0.004 to the hydrometer reading for every 10°F (6°C) that the electrolyte is above 80°F (27°C). Subtract 0.004 from the reading for every 10°F (6°C) that the electrolyte is below 80°F (27°C).

Before checking the specific gravity of a battery, load the battery with 15 amperes for one minute. If the battery is installed in the vehicle, this can be done by turning on the headlights without the engine running. **Table b** lists the percentage of charge based on specific gravity values.

Table b. Specific Gravity of Battery Electrolyte at 80°F (27°C)

| Specific gravity | State of charge |
|------------------|------------------|
| 1.265 | Fully charged |
| 1.225 | 75% charged |
| 1.190 | 50% charged |
| 1.155 | 25% charged |
| 1.120 | Fully discharged |

The battery is in satisfactory condition if the average specific gravity of the six cells is at least 1.225. If the specific gravity is above this level, but the battery lacks power for starting, determine the battery's service condition with a load voltage test, as described below. If the average specific gravity of the six cells is below 1.225, remove the battery from the luggage compartment and recharge. If, after recharging, the specific gravity varies by more than 0.005 between any two cells, replace the battery.

Battery Open-Circuit Voltage Test

Before making the test, load the battery with 15 amperes for one minute with a battery load-tester or turn on the headlights for about one minute without the engine running. Then disconnect the battery negative (-) cable and connect a digital voltmeter across the battery terminals. Open-circuit voltage levels are given in **Table c**.

If the open-circuit voltage is OK but the battery still lacks power for starting, make a load voltage test. If the open-circuit voltage is below 12.4 volts, recharge the battery and retest.

Table c. Open-Circuit Voltage and Battery Charge

| Open-circuit voltage | State of charge |
|----------------------|------------------|
| 12.6 V or more | Fully charged |
| 12.4 V | 75% charged |
| 12.2 V | 50% charged |
| 12.0 V | 25% charged |
| 11.7 V or less | Fully discharged |

Battery Load Voltage Test

A battery load tester is required for a load voltage test. The test is made by applying a high resistive load to the battery terminals and then measuring battery voltage. The battery should be fully charged for the most accurate results. The battery cables must be disconnected before making the test. If the voltage is below that listed in **Table d**, the battery should be replaced.

WARNING —
Always wear protective goggles and clothing when performing a load test.

Table d. Battery Load Test—Minimum Voltage (apply 200 amp load for 15 seconds)

| Ambient temperature | Voltage |
|---------------------|---------|
| 80°F (27°C) | 9.6 V |
| 60°F (16°C) | 9.5 V |
| 40°F (4°C) | 9.3 V |
| 20°F (-7°C) | 8.9 V |
| 0°F (-18°C) | 8.5 V |

Battery Charging

Discharged batteries can be recharged using a battery charger. The battery should be removed from the luggage compartment during charging.

Prolonged charging causes electrolyte evaporation to a level that can damage the battery. It is best to use a low-current charger (6 amperes or less) to prevent battery damage caused by overheating.

WARNING —
Hydrogen gas given off by the battery during charging is explosive. Do not smoke. Keep open flames away from the top of the battery, and prevent electrical sparks by turning off the battery charger before connecting or disconnecting it.

CAUTION —

- Battery electrolyte (sulfuric acid) can damage the car. If electrolyte is spilled, clean the area with a solution of baking soda and water.
- Always allow a frozen battery to thaw before attempting to recharge it.
- Always disconnect both battery cables and remove battery from vehicle during battery charging. Do not exceed 16.5 volts at the battery.

ALTERNATOR SERVICE

Before checking the alternator and regulator, make sure the battery is fully charged and capable of holding a charge. Check that the battery terminals are clean and tight and the alternator drive belt is properly tensioned and not severely worn.

Charging system, checking

CAUTION —
Do not disconnect the battery while the engine is running. Damage to the alternator and/or engine electronic systems may result.

1. Turn ignition key on. Check that the charge warning lamp comes on.

NOTE —
If the warning light does not come on, repair any wiring or bulb faults before continuing to check the charging system.

ALTERNATOR SERVICE

- Remove cooling duct or terminal cover from rear of alternator.
- Check for battery voltage between ground and terminal **B+** at back of alternator. Then turn ignition on and check for battery voltage between terminal **D+** and ground. See Fig. 3. If voltage is not present at either point, check wiring for faults.

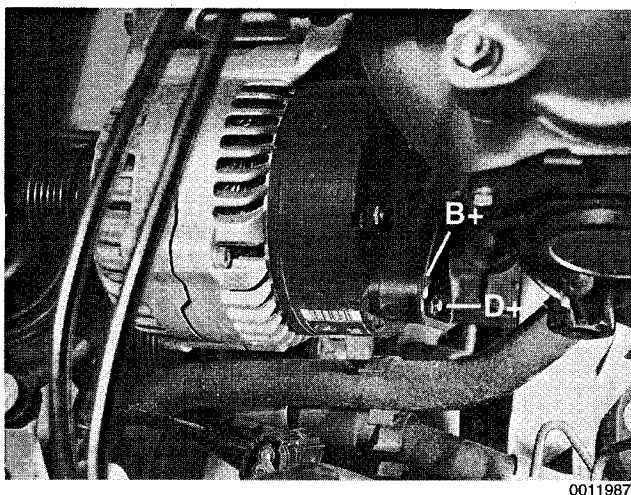

0011987

Fig. 3. Terminal **B+** is supplied battery voltage directly from the battery. Terminal **D+** is supplied battery voltage via the charge warning bulb when the key is on or the engine is running.

- If no faults are found up to this point, test alternator output using a load tester.
- If a load tester is not available, a crude output test can be done by running engine at about 2000 rpm and turning on electrical loads (fans, lights and rear window defroster, wipers). With all accessories on, battery voltage should be above 12.0 VDC.

Alternator, removing and installing (4-cylinder engine)

A replacement alternator should have the same rating as the original. Alternator manufacturer and ampere rating are normally marked on the alternator housing.

- Disconnect negative (-) battery cable.

CAUTION —

Prior to disconnecting the battery, read the battery disconnection cautions given at the front of this manual on page viii.

- Remove air cleaner upper section with mass air flow sensor.
- Remove terminal cover from rear of alternator. Disconnect wiring.
- Remove drive belt from alternator pulley. See **020 Maintenance program**.

NOTE —

If reusing drive belt, mark direction of rotation on belt before removing.

- On M44 engine with hydraulic belt tensioner: Remove tensioner idler pulley (upper roller) from alternator bracket.
- Remove upper and lower mounting bolts and lift out alternator. See Fig. 4.

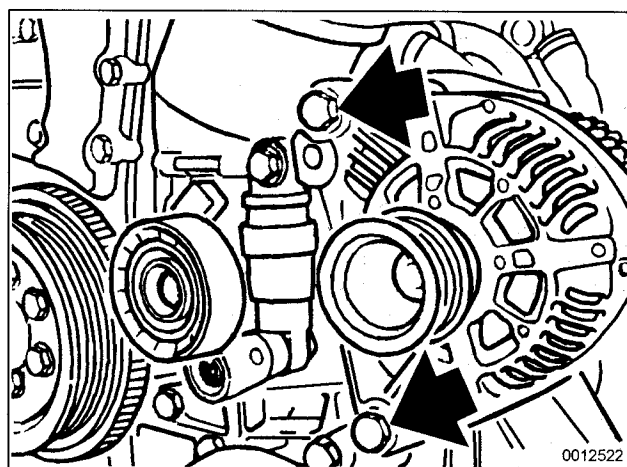

0012522

Fig. 4. Alternator mounting bolts (arrows).

- Installation is reverse of removal. Install drive belt as described in **020 Maintenance Program**.

Tightening Torques

- D+ wire to alternator (M6 nut) 7 Nm (53 in-lb)
- B+ wire to alternator (M8 nut) 13 Nm (10 ft-lb)
- Pulley to alternator (M16 nut) 60 Nm (44 ft-lb)

Alternator, removing and installing (6-cylinder engine)

A replacement alternator should have the same rating as the original. Alternator manufacturer and ampere rating are normally marked on the alternator housing.

1. Disconnect negative (-) battery cable.

CAUTION —

Prior to disconnecting the battery, read the battery disconnection cautions given at the front of this manual on page viii.

2. Remove alternator cooling duct and air filter housing assembly from car. Disconnect wiring from rear of alternator.
3. Remove radiator cooling fan and fan shroud. See 170 Radiator and Cooling System.

NOTE —

The radiator cooling fan nut (32 mm wrench) has left-hand threads.

4. Remove alternator drive belt from alternator pulley. On engines with hydraulic belt tensioner, remove tensioner idler pulley (upper roller) from alternator bracket. See Fig. 5.

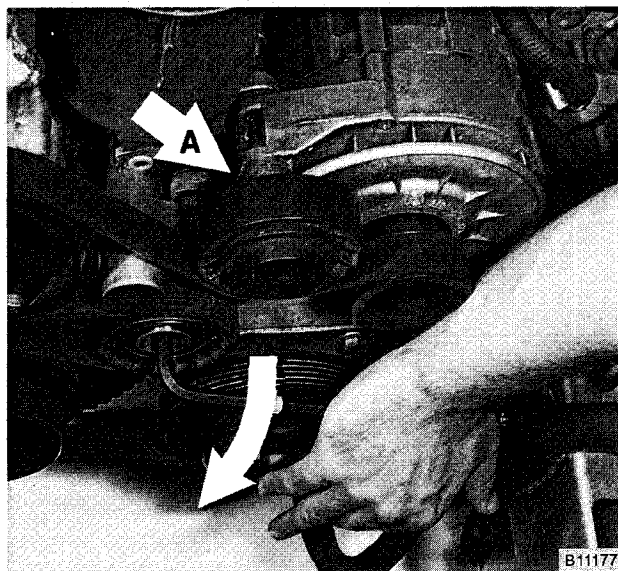

Fig. 5. Pry off cover from tensioner and then lever tensioner clockwise to release belt tension. Remove upper roller (A) once belt is removed.

NOTE —

If reusing drive belt, mark direction of rotation on belt before removing.

5. Remove upper and lower mounting bolts and lift out alternator.
6. Installation is reverse of removal. Note locating notches on tensioner idler pulley (upper roller) alternator bracket when installing pulley.

Tightening Torques

- D+ wire to alternator (M6 nut) 7 Nm (53 in-lb)
- B+ wire to alternator (M8 nut). 13 Nm (10 ft-lb)
- Pulley to alternator (M16 nut). 60 Nm (44 ft-lb)

Voltage regulator, removing and installing

1. Disconnect negative (-) cable from battery.
2. Remove alternator as described earlier.
3. Remove cooling duct from rear of alternator. See Fig. 6.

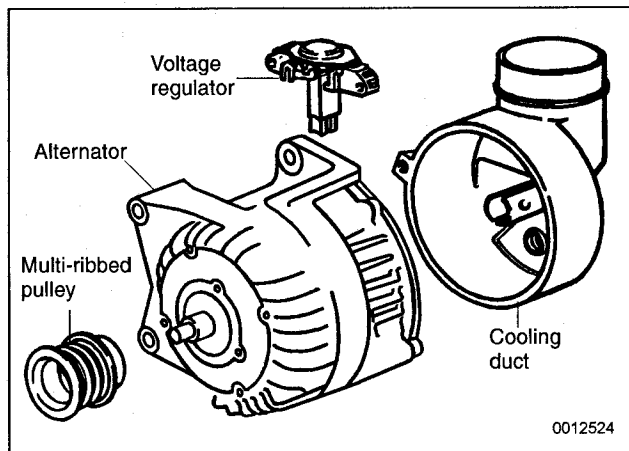

Fig. 6. Alternator assembly and related parts.

4. Remove voltage regulator mounting screws and remove regulator from alternator.
5. Installation is reverse of removal. Clean brush contact surfaces in alternator and check brush length as described later.

Alternator brushes, inspecting and replacing

Regulator brushes are not available as replacement parts from BMW. Replacement brushes may be available from aftermarket sources, however.

1. Remove voltage regulator as described above.
2. Clean brush contact surfaces and measure brush protrusion. See Fig. 7.

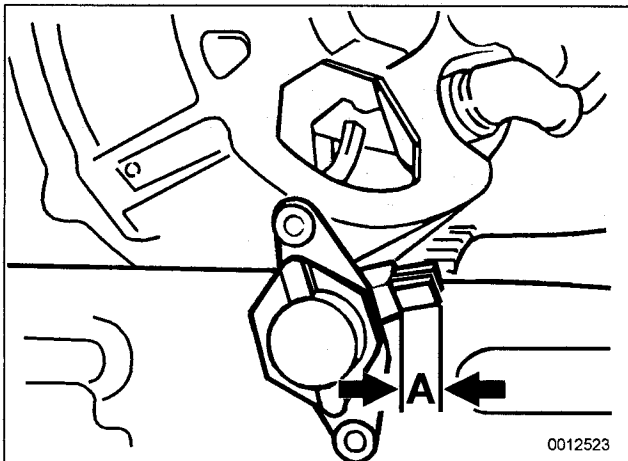

Fig. 7. Regulator brush protrusion (A).

Voltage Regulator

- Brush protrusion (minimum) 5 mm (1/4 in.)

3. To replace brushes, carefully and as quickly as possible, unsolder brush lead from brush holder terminal, withdrawing brush from holder at same time.
4. Remove any traces of solder from brush holder terminal using solder wick.
5. Fit spring into brush holder and insert new brush.
6. Guide brush lead into terminal and solder into place. Check for free movement of brushes when solder cools.
7. Check brush slip rings in alternator for wear. Lightly clean slip rings using fine abrasive cloth.
8. Reinstall regulator and alternator.

STARTER SERVICE

Starter Troubleshooting

If the starter turns the engine slowly or fails to operate when the ignition is in the start position, check the battery first. Inspect the starter wires, terminals, and ground connections for good contact. In particular, make sure the ground connections between the battery, the body and the engine are completely clean and tight. If no faults can be found, the starter may be faulty and should be replaced.

NOTE —

- Starting in 1/94, a factory-installed drive-away protection system, also referred to as EWS or EWS II, was used on all E36 cars. This system prevents operation of the starter when the system is engaged. See 515 Central Locking and Anti-theft.
- On cars with automatic transmission, a starter relay and a neutral safety switch are used to prevent the engine from starting in gear positions other than park or neutral. If voltage is not present at terminal 50 with the key in the start position, check these components

To make the most accurate check of the battery cables and starter wiring, make a voltage drop test on the cables and wiring as described in 600 Electrical System—General.

Check for battery voltage at terminal 50 of the starter motor with the key in the start position. See Fig. 8. If voltage is not present, check the wiring between the ignition switch and the starter terminal. If voltage is present and no other visible wiring faults can be found, the problem is most likely internal in the starter motor.

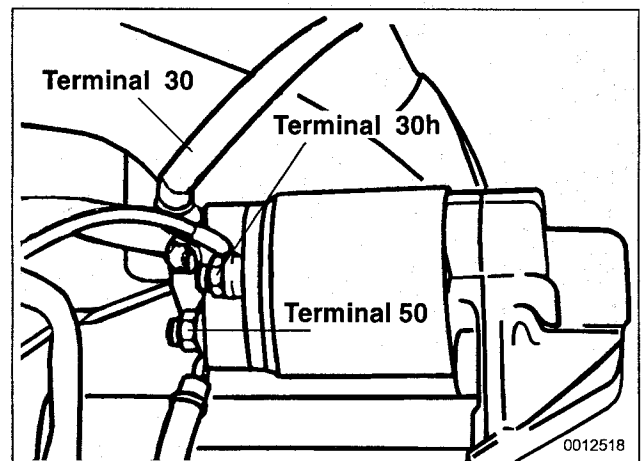

Fig. 8. Typical starter wiring terminal identification. Large wire at terminal 30 is direct battery voltage. Smaller wire at terminal 50 operates starter solenoid via ignition switch.

If the solenoid audibly clicks but the motor does not turn, switch on the lights and turn the key to the start position. If the lights go out while attempting to start, the battery cable may be loose or the starter may have a short circuit. If the lights stay on, the solenoid is most likely at fault.

Starter, removing and installing (4-cylinder engine)

1. Disconnect negative (-) cable from battery.

CAUTION —

Prior to disconnecting the battery, read the battery disconnection cautions given at the front of this manual on page viii.

2. Remove guide tube for oil dipstick.

3. Raise vehicle.

WARNING —

Make sure the car is stable and well supported at all times. Use a professional automotive lift or jack stands designed for the purpose. A floor jack is not adequate support.

4. Disconnect wiring from starter.
5. Remove top and bottom starter bolts. Bottom bolt must be removed from below car. Remove starter support bracket, if applicable.
6. Pull starter downward and turn until solenoid is at top, then remove from car.
7. Check starter pinion gear and flywheel teeth for damage.
8. Installation is reverse of removal.

Tightening Torques

- Starter to engine block (M10 bolt) . . . 50 Nm (37 ft-lb)
- Wire to terminal 50 (M6 nut) 6 Nm (53 in-lb)
- Wire to terminal 30 (M8 nut) 12 Nm (9 ft-lb)

Starter, removing and installing (6-cylinder engine with manual transmission)

The starter on a 6-cylinder car with manual transmission is removed from below.

1. Disconnect negative (-) battery cable.
2. Raise vehicle.
3. Remove reinforcing cross brace from under transmission, if applicable.
4. Remove cover from fuel filter and fuel lines on left side underneath car, if applicable. Detach fuel lines and harness connectors from retaining brackets, as necessary.
5. Disconnect wiring from starter.
6. Loosen and remove bolts and nuts fastening starter to transmission bell housing and/or engine block. Remove starter support bracket.
7. Remove starter from below.
8. Check starter pinion gear and flywheel teeth for damage.
9. Installation is reverse of removal.

Tightening Torques

- Reinforcing cross brace to chassis (M10) 42 Nm (31 ft-lb)
- Starter to engine block (M10 bolt) . . . 50 Nm (37 ft-lb)
- Support bracket to starter (M5 nut) . . . 5 Nm (44 in-lb)
- Support bracket to engine block (M10 bolt) 47 Nm (35 ft-lb)
- Wire to terminal 50 (M6 nut) 6 Nm (53 in-lb)
- Wire to terminal 30 (M8 nut) 12 Nm (9 ft-lb)

Starter, removing and installing (6-cylinder engine with automatic transmission)

The starter on a 6-cylinder car with automatic transmission is removed from above. It is necessary to remove the intake manifold and disconnect a number of electrical harness connectors.

1. Disconnect negative (-) battery cable.
2. Remove air plenum from rear of engine compartment. See **640 Heating and Air Conditioning**.
3. Remove top engine covers. See Fig. 9.

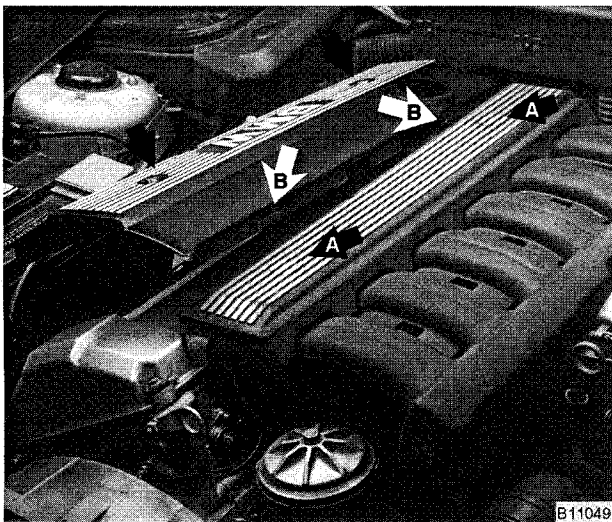

Fig. 9. Remove top engine cover by prying out plugs and removing nuts (A). Make sure rubber insulators (B) on either side of large cover do not fall off during cover removal.

4. Remove ignition coil harness connectors. Remove ground connection at front of cylinder head.
5. Remove two retaining bolts and lift off fuel injector harness connector strip. Carefully fold away all harnesses toward right side of engine compartment and place at base of windshield. See Fig. 10.
6. Remove intake manifold. See **113 Cylinder Head Removal and Installation**.
7. Disconnect wiring from starter.

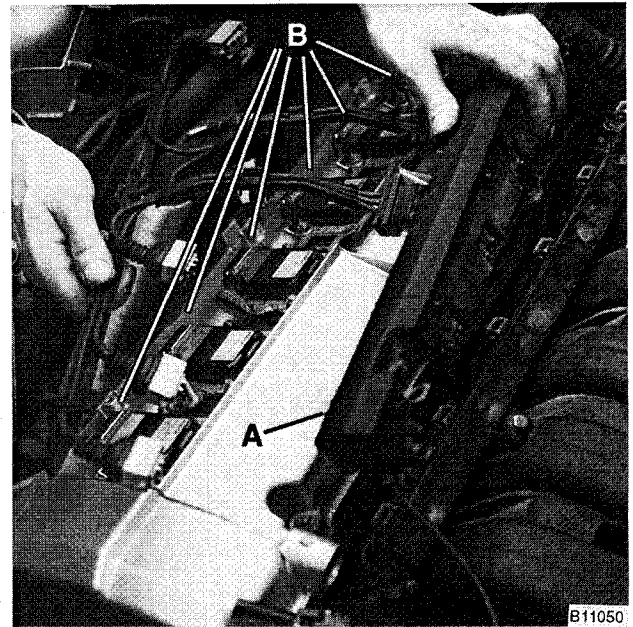

Fig. 10. Fuel injection harness (A) and ignition coil harness connectors (B) being lifted off engine to be placed at base of windshield. M50 engine shown. Other 6-cylinder engines are similar.

8. Loosen and remove bolts and nuts fastening starter to transmission bell housing and/or engine block. Remove starter support bracket.

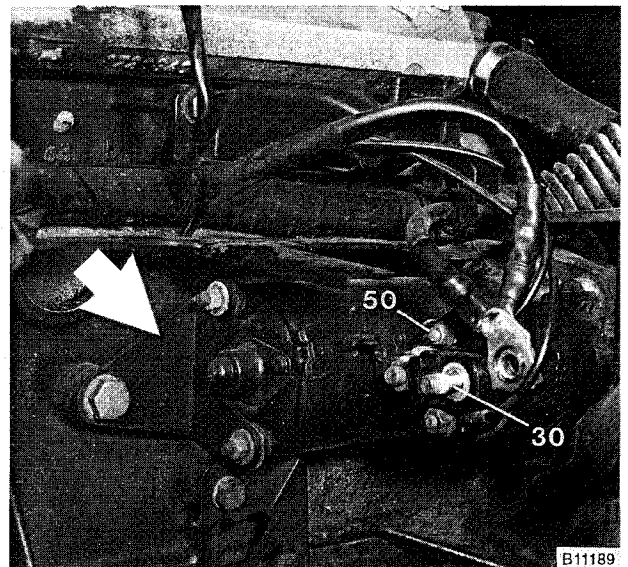

Fig. 11. Starter wiring terminals and support bracket (arrow). Intake manifold has been removed.

121-10 BATTERY, STARTER, ALTERNATOR

9. Remove starter from above.
10. Check starter pinion gear and flywheel teeth for damage.
11. Installation is reverse of removal.

Tightening Torques

- Intake manifold to cylinder head
 - M7 nut 15 Nm (11 ft-lb)
 - M8 nut/bolt 22 Nm (16 ft-lb)
- Starter to engine block (M10 bolt) . . . 50 Nm (37 ft-lb)
- Support bracket to starter (M5 nut) . . . 5 Nm (44 in-lb)
- Support bracket to engine block (M10 bolt) 47 Nm (35 ft-lb)
- Wire to terminal 50 (M6 nut) 6 Nm (53 in-lb)
- Wire to terminal 30 (M8 nut) 12 Nm (9 ft-lb)

Solenoid switch, removing and installing

1. Remove starter as described above.
2. Remove cover from solenoid switch.
3. Disconnect field winding strap between starter motor and solenoid switch.

NOTE —

The condition of the field winding strap is critical. If it is damaged, burned or partially melted through, a new or rebuilt starter motor is needed.

4. Remove solenoid switch mounting screws, and separate solenoid from starter. See Fig. 12.

CAUTION —

When installing field winding strap to starter, position it so that it does not contact the starter body.

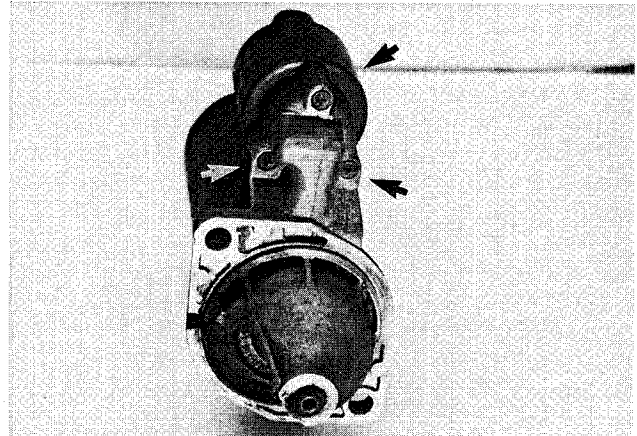

B11184

Fig. 12. Starter solenoid mounting screws (**arrows**) are tight. Use an impact screwdriver to loosen the screws.

5. Installation is reverse of removal. Lubricate solenoid piston with light grease.

Tightening Torque

- Field winding strap to starter (M8) 12 Nm (9 ft-lb)

